



American Accessories, Inc.

Phone (877) 465-5005

Fax (877) 465-4090

## Florida Series: Excel-1 Recessed Fast Air Hand Dryer

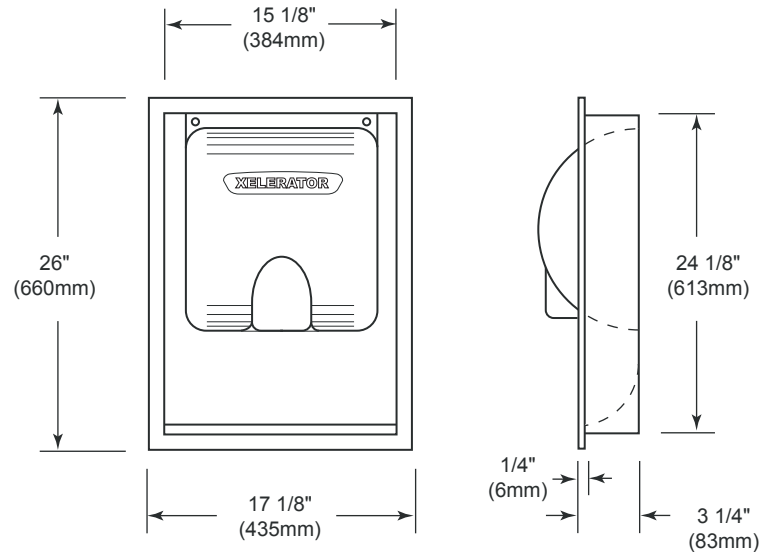
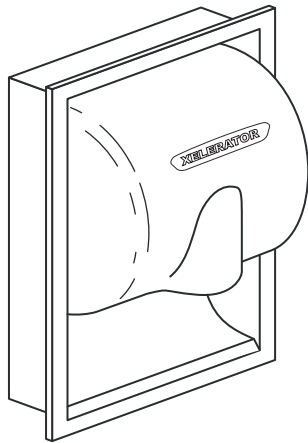

### SPECIFICATIONS:

#### Dryer:

Cover is one-piece, heavy duty, rib-reinforced, die-cast zinc alloy – lightweight, unbreakable and rustproof. All exposed surfaces are bright chrome plated or chip-proof, epoxy enamel. Unit is fastened to wall by two tamper-proof bolts. Wall plate equipped with two (2) 7/8" (22mm) diameter holes suitable for use with surface conduit. Internal parts coated and grounded per UL requirements.

#### Recessed Cabinet:

Fabricated of 22 gauge 18-8 type 304 stainless steel with #4 satin finish with 16 gauge 18-8 type 304 stainless steel dryer mounting plate. Stainless steel retention chain holds dryer in place when open for servicing. All welded construction.

### OVERALL DIMENSIONS:

17 1/8" W x 26" H x 6 11/16" D  
(435mm W x 660mm H x 173mm D)

### WALL OPENING:

15 5/8" W x 24 3/8" H x 4" D  
(397mm W x 619mm H x 102mm D)

### ADA GUIDE:

Bottom of blower unit shall be 38" (965mm) to 48" (1,219mm) above the finished floor.  
Consult local ADA codes.