

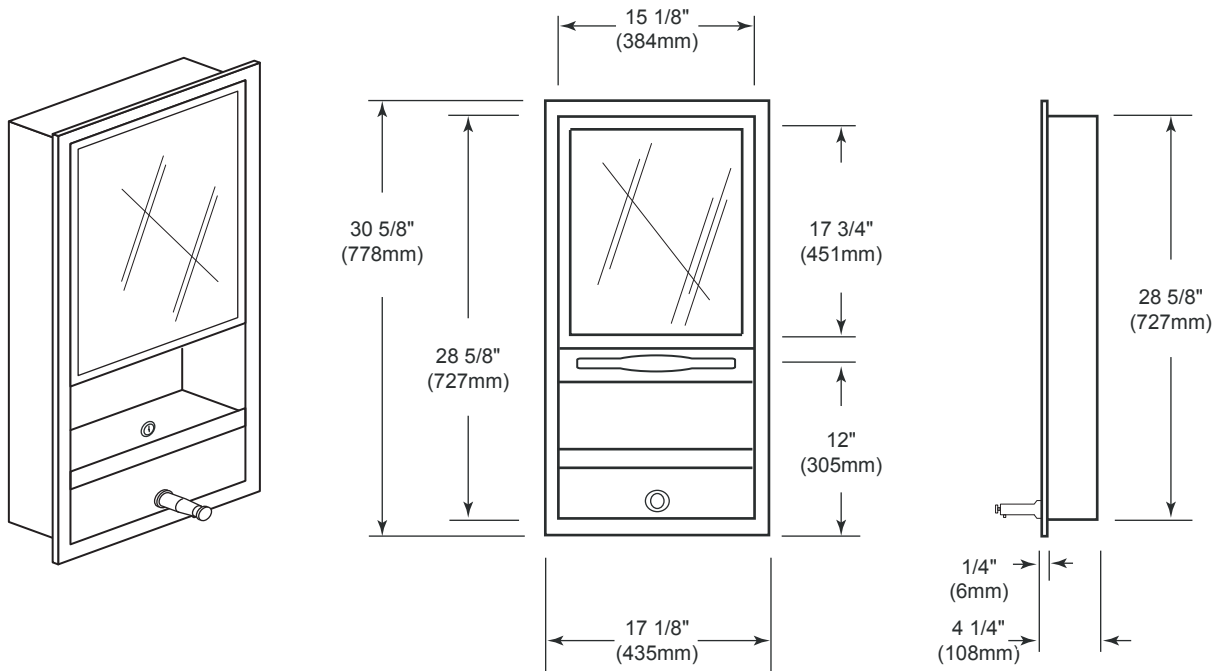

American Accessories, Inc.  
Phone (877) 465-5005  
Fax (877) 465-4090

## Maryland Series: MD-2 Multi-Purpose Unit



### SPECIFICATIONS:

- Unit fabricated of 18-8 type 304 stainless steel with #4 satin finish. Mirror glass door is 1/4"(6mm) float/plate glass mounted on cabinet with continuous stainless steel piano hinge and fitted with tumbler lock. Door provided with retainer. One piece seamless 22 gauge flange constructed with 1/4"(6mm) return for rigidity. All purpose valve provided. All welded construction.

### CAPACITY:

- 600 C-fold or 800 multi-fold towels.
- 1 gallon (3L) soap dispenser filled by opening tumbler locked cover.

### OVERALL DIMENSIONS:

- 17 1/8" W x 30 5/8" H x 4 1/4" D  
(435mm W x 778mm H x 108mm D)

### WALL OPENING:

- 15 5/8" W x 29 1/8" H x 4 1/4" D  
(397mm W x 740mm H x 108mm D)

### MOUNTING:

- 74"(1,880mm) to top of unit.

### ADA GUIDE:

Bottom edge of reflective surface should be mounted no more than 40"(1,016mm) above the finished floor. 74"(1,880mm) to top of unit. Access to paper towels should locate 15"(381mm) to 48"(1219mm) above the finish floor. Units should not project more than 4"(102mm) from the wall. Mounting location for push button dispensers are 44"(1,118mm) maximum above the finished floor. Push buttons and pistons should be operable with one hand without tight grasping, pinching, or twisting of the wrist. Activation of soap valves should not require more than 5 lbs. of force when completely filled.

### OPTIONS:

Available upon request.