

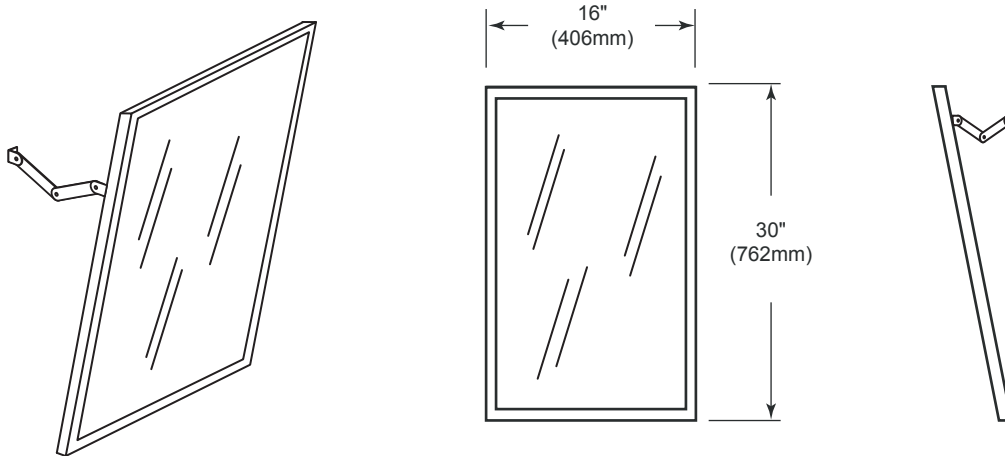

American Accessories, Inc.
Phone (877) 465-5005
Fax (877) 465-4090

Montana Series: MT-4 16"x30" Stainless Steel Adjustable Tilt Framed Mirror



SPECIFICATIONS:

- Unit fabricated of type 304 18-8 heavy stainless steel #4 satin finish. Roll formed angle 5/8"(17mm) x 3/4"(19mm), all
- welded construction with corners heliarc welded, ground and polished smooth. Back panel is fabricated of 20 gauge steel.
- Shock absorbing poly foam is placed between mirror and back panel. Mirror glass is first quality, 1/4"(6mm) plate/float
- glass. Guaranteed against silver spoilage for 25 years. Exceeds and meets all federal specifications DD-M-00411B C.S. 27.

INSTALLATION:

- Full surface mounted adjustable elbows and stainless steel piano hinge allow adjustment of tilt mirror for maximum of
- 5 1/4"(133mm) to flush against wall. Secure to finished wall. Mirror glass is replaceable in the field.

STANDARD FRAME SIZES: (wxh)

- 16x24 16x24
- 16x30 18x24
- 18x30 24x36

SPECIAL SIZES AVAILABLE:

- Maximum size is 30"(762mm)W x 36"(914mm)H.
-

OPTIONS:

- Tempered glass - specify suffix "T".
- Polished stainless steel - specify suffix "SS".
- Laminated glass - specify suffix "L".
- Plastic - specify suffix "P".