



American Accessories, Inc.

Phone (877) 465-5005

Fax (877) 465-4090

New Mexico Series: NM-10 Surface Mounted Napkin Disposal

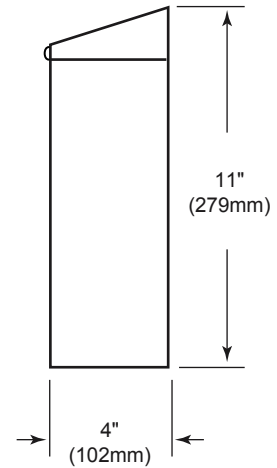
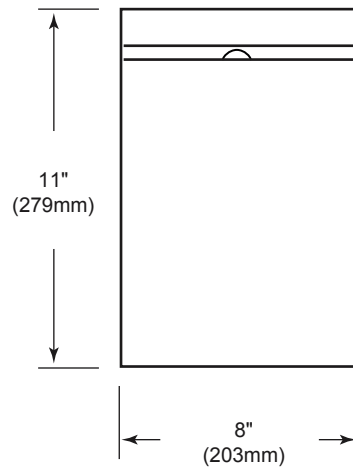
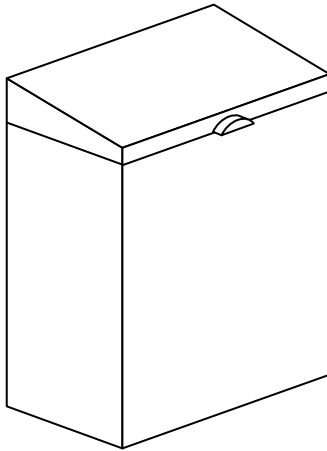

SPECIFICATIONS:

- Unit fabricated of 22 gauge 18-8 type 304 stainless steel with #4 satin finish. Door is mounted with full length stainless steel piano hinge. Top door provided with integral finger depression for easy opening. Bottom door provided with handle and dimpled catch locking device. Optional disposable wax paper liners. All welded construction.

CAPACITY:

- 1.2 gallons (4.6L).

OVERALL DIMENSIONS:

- 8" W x 11" H x 4" D
- (203mm W x 279mm H x 102mm D)
-

INSTALLATION:

Mount unit on wall or partition. For masonry walls, provide fiber plugs or expansion shields for use with sheet-metal screws, or provide 3/16" (5mm) toggle bolts or expansion bolts. For plaster or drywall construction, provide concealed backing to comply with local building codes, then secure unit with sheet-metal screws.

OPTIONS:

- NM-10W same as NM-10 except with white enamel finish.
- NM-10TG same as NM-10 except with titanium gold finish.

ADA GUIDE:

- Hinged panels covering waste receptacle openings should not require more than 5 pounds of force to open. Units should
- not project more than 4"(102mm) from the wall.