



American Accessories, Inc.

Phone (877) 465-5005

Fax (877) 465-4090

New Mexico Series: NM-40

Napkin Disposal

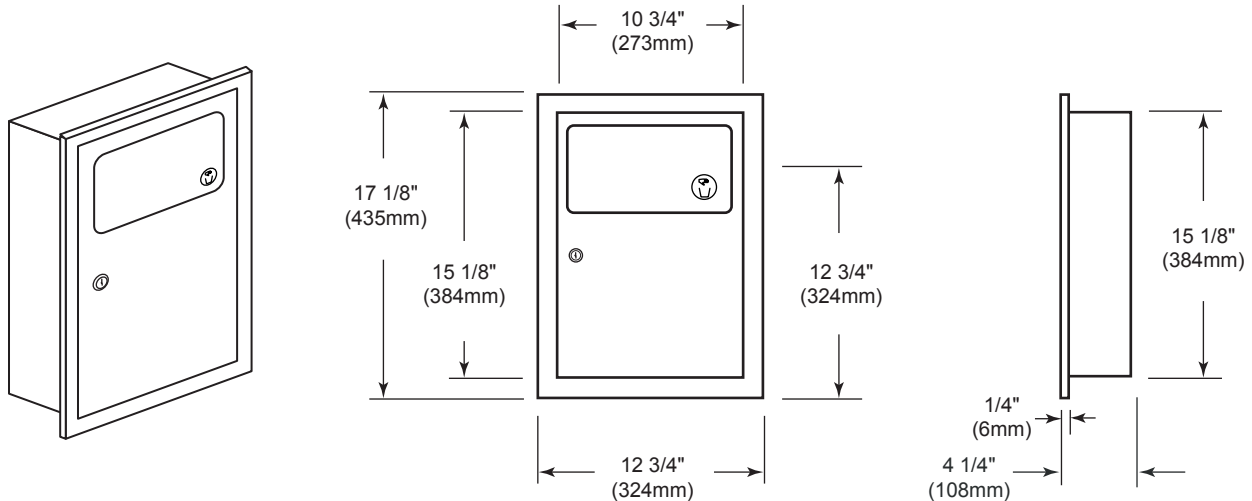

SPECIFICATIONS:

- Unit fabricated of 18-8 type 304 stainless steel with #4 satin finish. Doors are 18 gauge, warp free, mounted with
- continuous stainless steel piano hinge, and fitted with tumbler lock. Self-closing push door is mounted with continuous
- stainless steel piano hinge. One-piece 22 gauge flange has 1/4" (6mm) return for rigidity. Stainless steel inner container is
- removable for servicing. All welded construction.

CAPACITY:

- 1.2 gallons (4.6L).

INSTALLATION:

- Provide framed wall opening. Recessed depth required is 4 1/4" (108mm) from the finished face of wall. If installing where
- unit projects above wainscot, provide filler to prevent gaps. If installing in block walls, use metal expansion shields.
- 1/8" (3mm) gap recommended between units for door clearance.

OVERALL DIMENSIONS:

- 12 3/4" W x 17 1/8" H x 4 1/4" D
- (324mm W x 435mm H x 108mm D)

WALL OPENING:

- 11 1/4" W x 15 5/8" H x 4 1/4" D
- (286mm W x 397mm H x 108mm D)

MOUNTING:

- 34" (864mm) to top of unit.

ADA GUIDE:

- Hinged panels covering waste receptacle openings should not require more than 5 lbs. of force to open. Units should not
- project more than 4" (102mm) from the wall. Operable with one hand without tight grasping, pinching, or twisting of the
- wrist.