



American Accessories, Inc.

Phone (877) 465-5005

Fax (877) 465-4090

New Mexico Series: NM-60

Dual Access Napkin Disposal

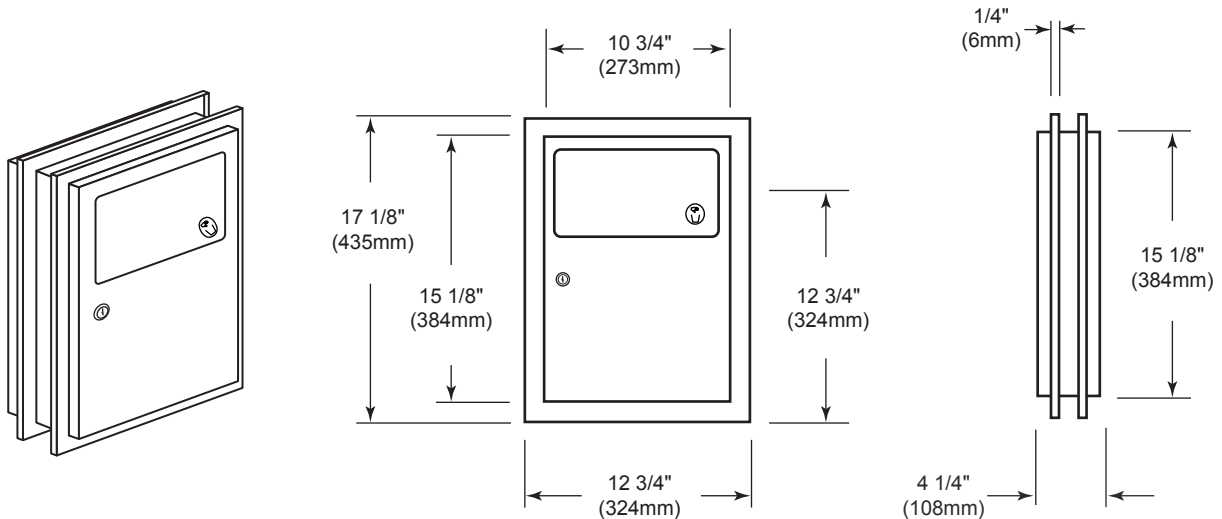

SPECIFICATIONS:

- Unit fabricated of 18 and 22 gauge 18-8 type 304 stainless steel with #4 satin finish. Door is warp free, mounted with continuous stainless steel piano hinge, and fitted with tumbler lock. Self-closing push door is mounted with full length concealed stainless steel piano hinge and has international waste symbol. One-piece flange has 1/4"(6mm) return for rigidity. Stainless steel inner container is removable for servicing. Optional disposable was paper liners. All welded construction.

CAPACITY:

- 1.2 gallons (4.6L).

INSTALLATION:

- Mount in toilet partition 1/2"(13mm) to 1 1/4"(32mm) thick, centered through a cut out. For installation place unit firmly in partition opening, make sure flange is tight against the surface then secure to partition with screws.

OVERALL DIMENSIONS:

- 12 3/4" W x 17 1/8" H x 4" D
- (324mm W x 435mm H x 102mm D)

PARTITION OPENING:

- 11 1/4" W x 15 5/8" H
- (286mm W x 397mm H)

MOUNTING:

- 34"(864mm) to top of unit.

ADA GUIDE:

- Hinged panels covering waste receptacle openings should not require more than 5 lbs. of force to open. Units should not project more than 4"(102mm) from the wall.