

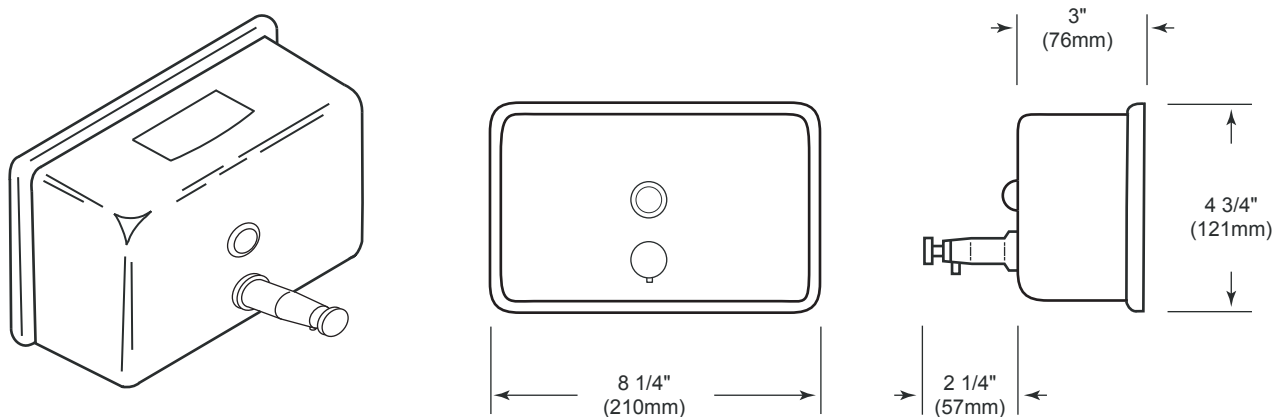

American Accessories, Inc.  
Phone (877) 465-5005  
Fax (877) 465-4090

## South Dakota Series: SD-58AP Soap Dispenser



### SPECIFICATIONS:

- Unit fabricated of 18-8 type 304 stainless steel with #4 satin finish. Unit is refilled from the top through locked opening.
- 20 gauge tank is heliarc welded to stainless steel concealed back. Non-corroding valve dispenses viscous lotion soap. Unit
- has sight level indicator for easy inspection. Concealed mounting bracket.
- 

### CAPACITY:

- 40 ounces.

### INSTALLATION:

- Mount wall plate (flat side) against wall surface with screws provided. Unlock and lift filler plate. Unscrew
- machine screw, which go through back panel of unit. Slip unit over wall plate and tighten machine screw until
- secure.

### OVERALL DIMENSIONS:

- 8 1/4" W x 4 3/4" H x 5 1/4" D
- (210mm W x 121mm H x 133mm D)
- 

### MOUNTING:

- Mounting location for push button dispenser is 44"(1,118mm) maximum above the finished floor.

### ADA GUIDELINES:

- Push buttons and pistons should be operable with one hand and without tight grasping, pinching or twisting of the wrist.
- Activation of soap valves should not require more than 5 pounds of force when unit is completely filled.