

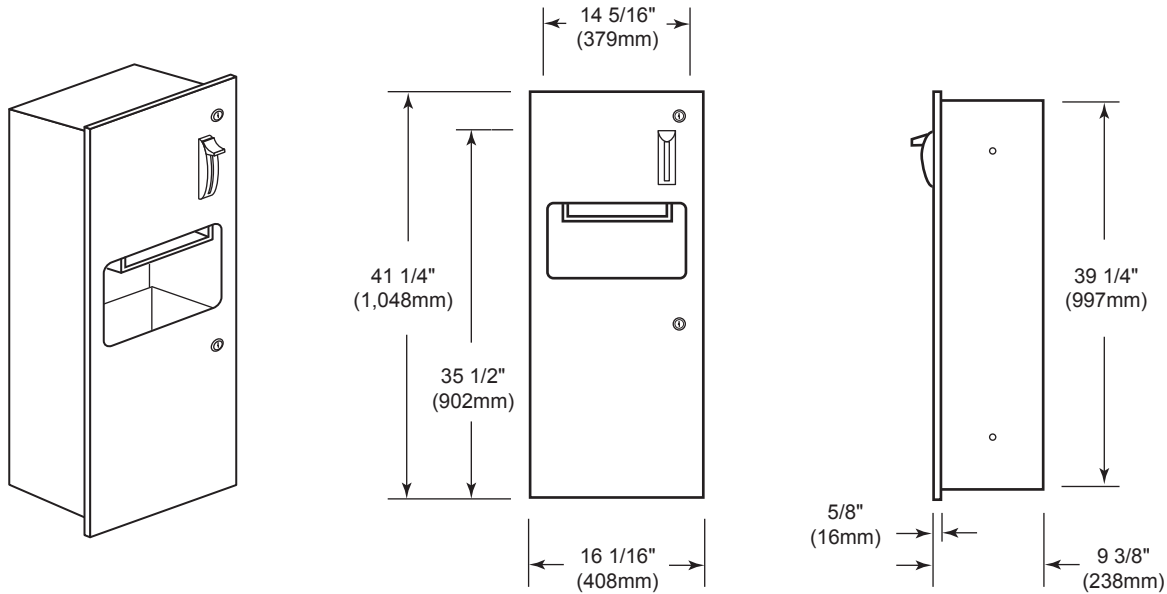

American Accessories, Inc.
 Phone (877) 465-5005
 Fax (877) 465-4090

Texas Series: TX-12RT Roll Paper Towel & Waste Receptacle



SPECIFICATIONS:

- Unit fabricated of 18-8 type 304 heavy stainless steel with #4 satin finish. Door is 18 gauge, mounted with a
- continuous stainless steel piano hinge, and fitted with two (2) tumbler locks. One piece construction with a 5/8" (16mm)
- return for extra rigidity. Removable for servicing. All welded construction.

CAPACITY:

- Dispenses standard core rolls 8" (203mm) or 9" (229mm) wide, 800' (243,840mm) length. Mechanism is adjustable to
- dispense preset lengths of towel per stroke.

INSTALLATION:

- Provide framed wall opening of 14 9/16" (370mm)W x 39 3/4" (1,010mm)H. Recessed depth required is 9" (229mm)
- from the finished floor. Coordinate plans with mechanical engineers to avoid protrusion from opposite wall, pipes,
- conduits, electrical wires, etc. If installing where unit projects above wainscot, provide filler to prevent gap. If installing
- in block walls, use metal expansion shields.

OVERALL DIMENSIONS:

- 16 1/16" W x 41 1/4" H x 9 3/8" D
- (408mm W x 1,048mm H x 238mm D)
-
-

WALL OPENING:

- 14 9/16" W x 39 3/4" H x 9" D
- (370mm W x 1,010mm H x 229mm D)

MOUNTING:

- 72" (1,829mm) to top of unit, 45 1/2" (1,156mm) for handicapped.

ADA GUIDE:

- Access to paper towels should be 15" (381mm) to 48" (1,219mm) above the finished floor. Units should not project more
- than 4" (102mm) from the wall. Operable without tight grasping, pinching, or twisting of the wrist.
-