

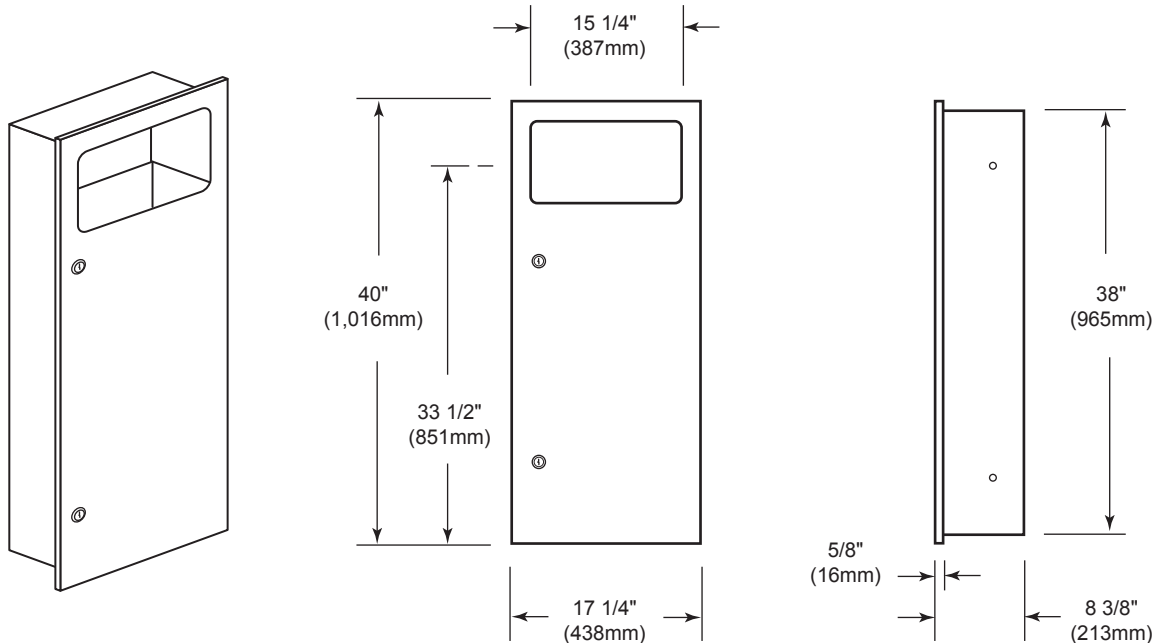

American Accessories, Inc.
Phone (877) 465-5005
Fax (877) 465-4090

Washington Series: WA-15 Recessed Waste Receptacle



SPECIFICATIONS:

- Unit fabricated of 18 gauge 18-8 type 304 stainless steel with #4 satin finish. Door is mounted with continuous stainless steel piano hinge and fitted with two (2) tumbler locks. Constructed with 5/8" (16mm) return for rigidity. Door will conceal flange from view. Removable stainless steel inner container. All welded construction.

CAPACITY:

- 12 gallons (45L).

INSTALLATION:

- Provide framed wall opening 15 3/4" (400mm)W x 38 1/2" (978mm). Recessed depth required is 8" (203mm) from the finished face of wall. If installing where unit projects above wainscot, provide filler to prevent gaps. If installing in block walls, use metal expansion shields. 1/8" (3mm) gap recommended between units for door clearance. Secure unit with #10x 11/4" sheet metal screws.

OVERALL DIMENSIONS:

- 17 1/4" W x 40" H x 8 3/8" D
- (438mm W x 1,016mm H x 213mm D)
-

WALL OPENING:

- 15 3/4" W x 38 1/5" H x 8" D
- (400mm W x 978mm H x 203mm D)

OPTIONS:

- WA-15F same as WA-15 but with 2" (51mm) skirt for semi-recessing.
- WA-15FS same as WA-15 but with 7 3/4" (197mm) skirt for surface mounting.

ADA GUIDE:

- Access to paper towels should be 15" (381mm) to 48" (1,219mm) above the finished floor. Hinged panels covering waste receptacle openings should not require more than 5 lbs. of force to open. Units should not project more than 4" (102mm) from the wall. Operable without tight grasping, pinching, or twisting of the wrist.
-