



American Accessories, Inc.

Phone (877) 465-5005

Fax (877) 465-4090

## Washington Series: WA-6 Recessed Waste Receptacle

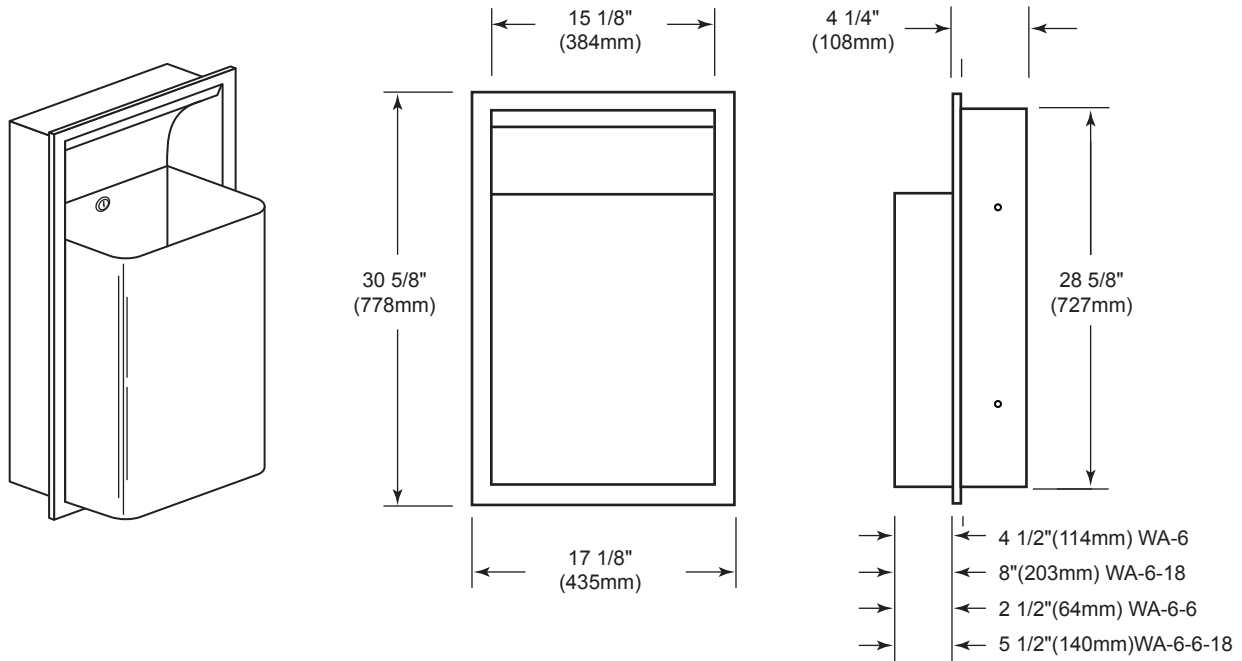

### SPECIFICATIONS:

- Unit fabricated of 22 gauge 18-8 type 304 stainless steel with #4 satin finish. One-piece seamless flange with 1/4" (6mm) return for extra rigidity. Waste receptacle hemmed at top and bottom and fitted with a tumbler lock. Removable for servicing. All welded construction.

### CAPACITY:

- 12 gallons (45L).

### INSTALLATION:

- Provide framed wall opening. Recessed depth required is 4 1/4" (108mm) from the finished face of wall. If installing where unit projects above wainscot, provide filler to prevent gaps. If installing in block walls, use metal expansion shields.
- 1/8" (3mm) gap recommended between units for door clearance.

### OVERALL DIMENSIONS:

- 17 1/8" W x 30 5/8" H x 4 1/4" D
- (435mm W x 778mm H x 108mm D)

### WALL OPENING:

- 15 5/8" W x 29 1/8" H x 4 1/4" D
- (397mm W x 740mm H x 108mm D)

### MOUNTING:

- 37" (940mm) to top of unit, 51" (1,295mm) for handicapped.

### ADA GUIDELINE:

- Access to paper towels should be 15" (381mm) to 48" (1,219mm) above the finished floor. Hinged panels covering waste receptacle openings should not require more than 5 lbs. of force to open. Unit should not project more than 4" (102mm) from the wall. Operable with one hand without grasping, pinching, or twisting of the wrist.
-